



Keeping Industry Turning



WEX3 Flameproof
IE3 Efficiency

**BROOK
CROMPTON**
a WOLONG company

About Us



2

Wolong Group

One of the world's top three motor and drive manufacturers.

Wolong has over fifty first-level subsidiaries, more than 15,000 employees, total assets of 4.3 billion USD, and annual sales of 5.4 billion USD in 2019. The group was founded in 1984 and listed on the Shanghai Stock Exchange in June 2002.

With its reliable design, Wolong motors are constantly powering fans, pumps, compressors, conveyors, etc.: Driven by technology and innovation.

The main products are leading the international and domestic mainstream markets and supporting many national key projects.

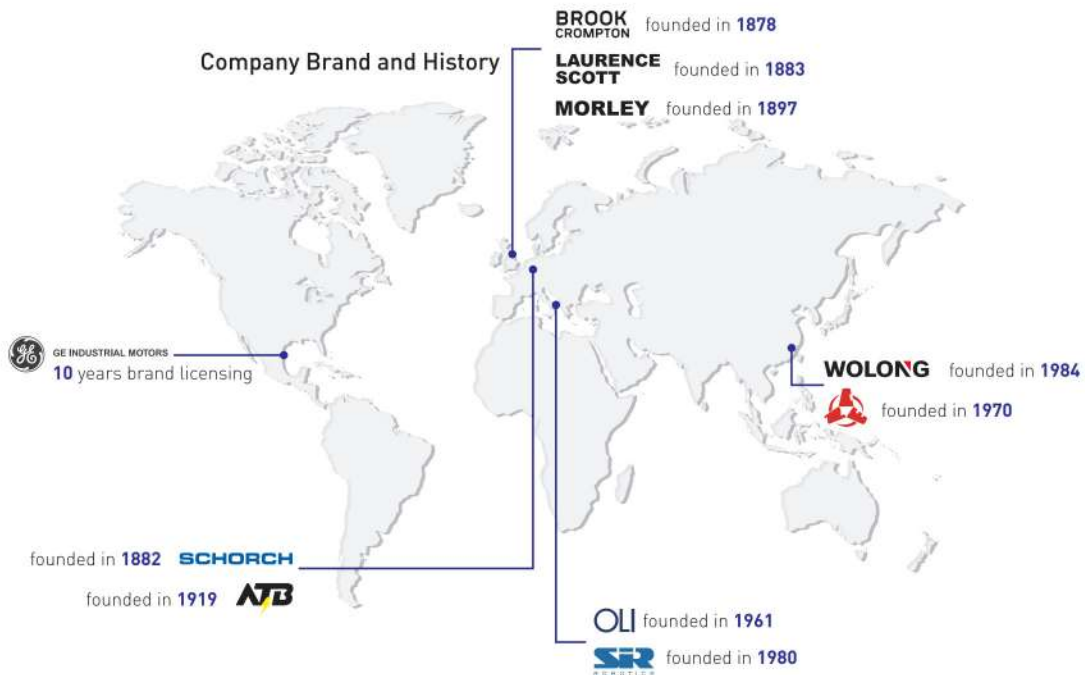

Brook Crompton

Brook Crompton is a global leader in the development of high-efficiency motors. In 1878, it completed the development and production of the first series of high-efficiency motors in the United Kingdom.

It enjoys a good reputation in the electric drive industry in continental Europe, Asia Pacific and North America, and has become the world's leading motor distribution brand.



Product Description



Product overview

WEX3 series high efficiency flameproof three-phase asynchronous motor is jointly developed by European and Asian technical teams, fully absorbing the excellent genes of European explosion-proof motor design. Owing the new appearance design, its improves the safety performance of the motor, expands the explosion-proof type and enhances the frequency conversion ability. This product is a newly upgraded product that being launched by Wolong all over the world.

Excellent features of WEX3 series motors

- IE3 Efficiency
- II 2G Ex db and db eb terminal box
- Universal foot and Fixed foot design
- VFD ready up to 690V
- Terminal box rotatable in 90° steps
- Various bearing configurations, ball, roller, angular
- Heater
- Auxiliary terminal boxes
- Painting schemes up to Cx

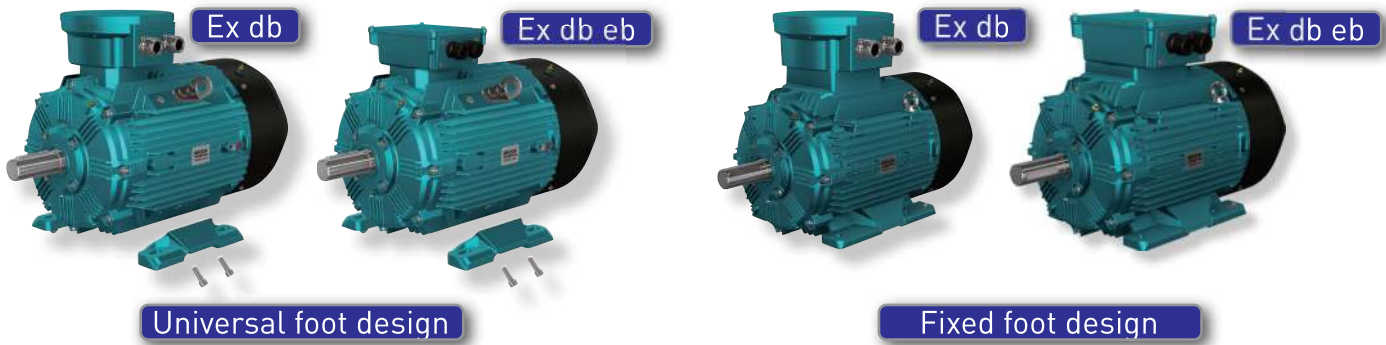

Applications

This series of motors can be used in the explosive circumstances that mixed with combustible gas or steam and air, such as oil, coal, chemical industry, metallurgy, electric power, oil and gas pipeline, mine, port, machinery industry, etc. It is an ideal driving equipment which is widely applied in various of machinery equipments, such as pumps, fans, compressors, conveyors, mixers, crushers, hoists, etc.



Product Description



4

Nomenclature

WEX3 160M1-2

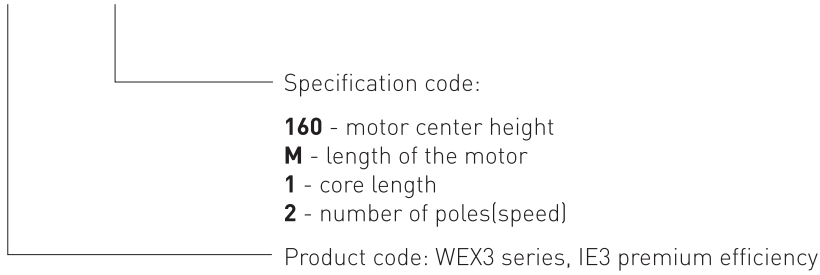

Ex-mark

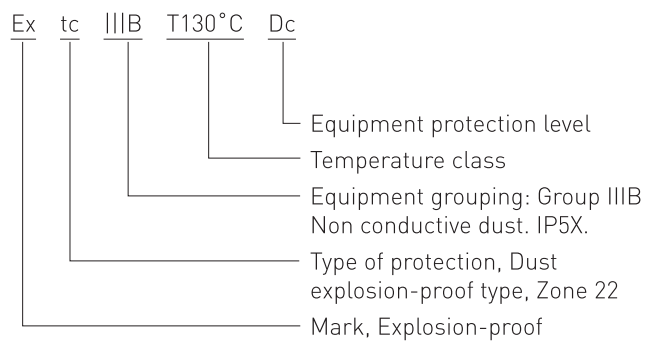
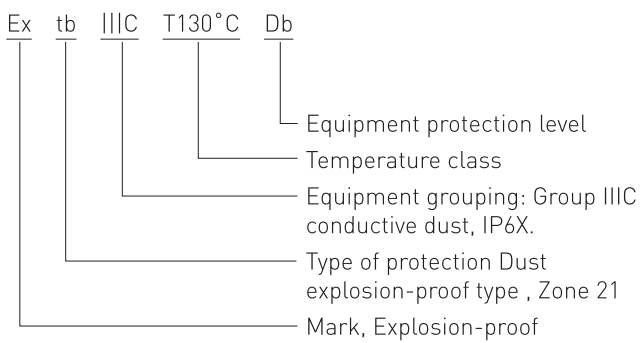
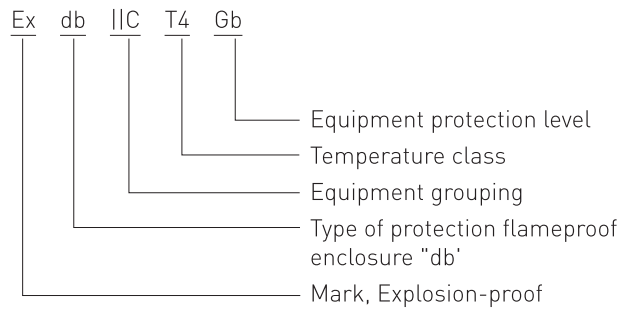
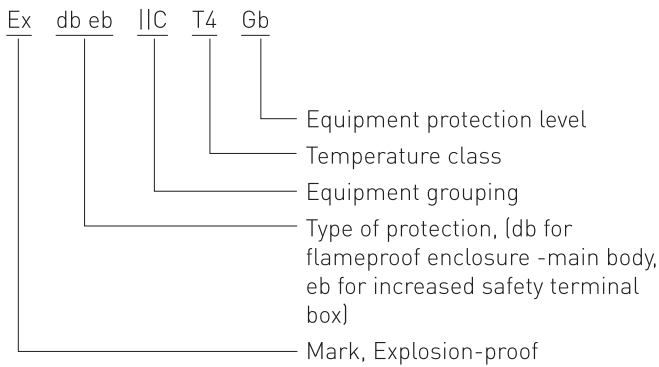

Certificates and Standards



In order to ensure the universal application of the motors within future global markets, conformity certificates have been issued for the motors through various international certification authorities and notified bodies.

GB/T19001-2016/ISO 9001: 2015 for the Quality Management System



GB/T24001-2016/ISO14001: 2015 for the Environmental Management System



GB/T 28001-2011/OHSAS 18001: 2007 for the Occupational Health and Safety Management System



Explosion protection certifications

CNEX GLOBE for Europe

IECEX worldwide

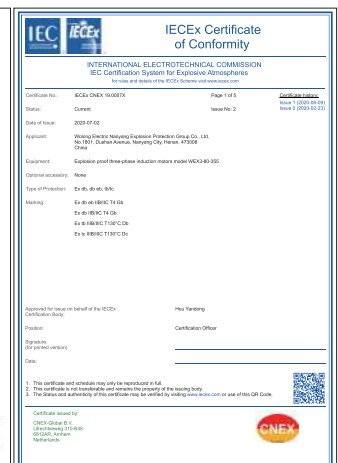

- Explosion proof types: gas explosion proof, dust explosion proof
- Gas explosion proof: Ex db eb IIB/IIC T4 Gb(the main body is flameproof type and the terminal box is increased safety type), Ex db IIB/IIC T4 Gb(both the main body and the terminal box are flameproof type)
- Dust explosion-proof: Ex tb IIIC T130°C Db(conductive dust Zone 21, IP6X), Ex tc IIIB T130°C Dc(non-conductive dust Zone 22, IP6X)

- IECEX CNEX 19.0007X Ex db eb IIB/IIC T4 Gb
- IECEX CNEX 19.0007X Ex db IIB/IIC T4 Gb
- IECEX CNEX 19.0007X Ex tb IIIC T130°C Db
- IECEX CNEX 19.0007X Ex tc IIIB T130°C Dc

- CE₀₄₇₀ Ex II2 G Ex db eb IIB/IIC T4 Gb, CNEX 19ATEX 0006X
- CE₀₄₇₀ Ex II2 G Ex db IIB/IIC T4 Gb, CNEX 19ATEX 0006X
- CE₀₄₇₀ Ex II2 D Ex tb IIIC T130°C Db, CNEX 19ATEX 0006X
- CE Ex II3 D Ex tc IIIB T130°C Dc, CNEX 19ATEX 0006X

Specification



6

Specification

Specification	Standard product	Options
Frame size	80 to 355	-
Rated power	0.37 to 375kW	-
Efficiency level	IE3	-
Number of poles	2P, 4P, 6P, 8P	10P, 12P, 14P, 16P
Rated voltage	400V	On request
Frequency	50Hz	60Hz
Duty	S1	S2-S10
Ambient temperature	-20°C to +40°C	-40°C to +60°C
Altitude	≤1000 m	On request
Humidity	≤90%	-
Mounting option	B3, B5, B35, B14, V1	B34,V6 etc.
Terminal box position	Top	Right hand side ,left hand side
Type of cable entry	Cable grand	-
Enclosure	IP55	IP66,IP56,IP65
Inverter operation	Inverter use ready up to 500V acc. to IEC60034-25: 2014 chapter 18	Reinforced insulation required for operation at 690V acc. to IEC60034-25: 2014 chapter 7
Insulation	Class F	Class H
Cooling type	IC411	-
Shaft key	Type A	
Lubrication	80 to 280 Sealed 315 to 355 Regreasing	160 to 280 Regreasing
Connection	<4kW: "Y" connection ≥4kW : "Δ" connection	-
Fan material	Engineered plastic	Cast aluminum
Rotation direction	Clockwise rotation at drive end	On request
Winding temperature measurement	Thermistors (PTC)80 to 355	RTDs 160 to 355
Bearing temperature measurement	-	RTDs 160 to 355
Anti condensation heater	-	80 to 355
Vibration monitoring	-	160 to 355
Paint specification (equivalent to IEC12944)	C3	C4,C5,Cx

Standards



Standards, codes, regulations and specifications

Standards			
Standard name	IEC	EN	GB
Rotating electrical machines Rating and operating behavior	IEC 60034-1	EN 60034-1	GB/T755
Process for determining losses and efficiency of rotating electrical machines by means of testing	IEC 60034-2-1	EN 60034-2-1	GB/T1032
Protection types of rotating electrical machines based on overall construction(IP-Code) - Introduction	IEC 60034-5	EN 60034-5	GB/T 4942.1
Classification of the cooling processes (IC code)	IEC 60034-6	EN 60034-6	GB/T 1993
Classification of the design types, the installation types and the terminal box location (IM-Code)	IEC 60034-7	EN 60034-7	GB/T 997
Terminal markings and direction of rotation	IEC 60034-8	EN 60034-8	GB 1971
Noise emission limit values	IEC 60034-9	EN 60034-9	GB/T 10069.3
Starting performance of three-phase motors with squirrel-cage rotor, except for pole-changing motors	IEC 60034-12	EN 60034-12	-
Mechanical vibrations of certain machines with a shaft height of 56 mm and higher; measurement, evaluation and limit values of the vibration	IEC 60034-14	EN 60034-14	GB/T 10068
Efficiency classification of three-phase motors with squirrel-cage rotors, except for pole-changing motors (IE code)	IEC 60034-30-1	EN 60034-30	GB18613
Balancing value	ISO 1940	-	-
IEC standard voltages IEC	IEC 60038	-	-
Evaluation and classifications of electric insulation according to its thermal behavior	IEC 60085	-	GB/T 11021
Three-phase induction motors for general use with standardized dimensions and powers	IEC 60072-1	EN 50347	GB/T 4772.1
Explosive atmosphere - Part 0: Equipment General requirements	IEC 60079-0	EN 60079-0	GB 3836.1
Explosive atmosphere - Part 1: Equipment protection through flameproof enclosure "d"	IEC 60079-1	EN 60079-1	GB 3836.2
Explosive atmosphere - Part 7: Equipment protection through increased safety "e"	IEC 60079-7	EN 60079-7	GB 3836.2
Electrical equipment for use in areas with inflammable dust - protection of the housing	IEC 60079-31	EN 60079-31	-

Product matrix



8

Motor type

Frame Size	Synchronous speed r/min							
	3000	1500	1000	750	600	500	429	375
	Power (kW)							
80M1	0.75	0.55	0.37	-				
80M2	1.1	0.75	0.55	-				
90S	1.5	1.1	0.75	-				
90L	2.2	1.5	1.1	-				
100L1	3	2.2	1.5	0.75				
100L2	3	3	1.5	1.1				
112M	4	4	2.2	1.5				
132S1	5.5	5.5	3	2.2				
132S2	7.5	5.5	3	2.2				
132M1	-	7.5	4	3	-			
132M2	-	7.5	5.5	3		-		
160M1	11	11	7.5	4				-
160M2	15	11	7.5	5.5				
160L	18.5	15	11	7.5				
180M	22	18.5	-	-				
180L	-	22	15	11				
200L1	30	30	18.5	15				
200L2	37	30	22	15				
225S	-	37	-	18.5	15			
225M	45	45	30	22	18.5			
250M	55	55	37	30	22	18.5		
280S	75	75	45	37	30	22	18.5	
280M	90	90	55	45	37	30	22	
315S	110	110	75	55	45	37	30	22
315M	132	132	90	75	55	45	37	30
315L1	160	160	110	90	75	55	45	37
315L	185	185	-	-	-	-	-	-
315L2	200	200	132	110	90	75	55	45
355S1	185	185	160	132	90	75	75	55
355S2	200	200	160	132	90	75	75	55
355M1	220	220	185	160	110	90	90	75
355M2	250	250	200	160	132	110	110	90
355L1	280	280	220	185	160	132	132	110
355L2	315	315	250	200	185	160	132	110
355LX1	355	355	280	220	200	185	160	132
355LX2	375	375	315	250	-	-	-	-

Note: the Numbers 1 and 2 after S, M and L respectively represent different powers at the same frame size and rotating speed.

Performance data



50Hz 3000 min⁻¹ (2 pole)

Type	kW	I _N (A)			rpm	η (%)			cos Φ			T _N N.m	I _s / I _N	T _L / T _N	T _B / T _N	L _w / L _p dB(A)	kg·m ²	kg
		230V	400V	690V		1.0P _N	0.75P _N	0.5P _N	1.0P _N	0.75P _N	0.5P _N							
WEX3-80M1-2	0.75	2.78	1.60	-	2864	80.7	81.4	80.1	0.83	0.79	0.71	2.5	6.6	3.1	3.2	62/50	0.0012	32
WEX3-80M2-2	1.1	4.00	2.30	-	2852	82.7	83.2	82.3	0.83	0.81	0.73	3.7	6.6	3.1	3.2	62/50	0.0014	34
WEX3-90S-2	1.5	5.39	3.10	-	2881	84.2	85.4	83.8	0.84	0.81	0.75	5	7.3	2.9	3.4	67/55	0.0016	40
WEX3-90L-2	2.2	8.17	4.70	-	2881	85.9	86.8	85.1	0.85	0.8	0.74	7.3	7.9	3.6	3.73	67/55	0.0018	42
WEX3-100L-2	3	10.09	5.80	-	2907	87.1	88.9	87.2	0.87	0.83	0.77	9.9	8.2	2.6	3.135	74/62	0.0058	63
WEX3-112M-2	4	-	7.5	4.3	2903	88.1	88.7	88.2	0.88	0.84	0.77	13.2	7.6	2.5	3.55	77/65	0.0076	63
WEX3-132S1-2	5.5	-	10.3	6.0	2916	89.2	89.5	88.3	0.88	0.84	0.77	18	8.7	3.0	3.9	79/67	0.0159	80
WEX3-132S2-2	7.5	-	13.6	7.9	2909	90.1	91.1	90.4	0.89	0.86	0.8	24.6	8.4	2.95	3.77	79/67	0.0195	87
WEX3-160M1-2	11	-	20.0	11.6	2943	91.2	91.8	91.5	0.89	0.86	0.8	35.7	7.9	2.9	3.8	81/68	0.05	174
WEX3-160M2-2	15	-	26.7	15.5	2940	91.9	93.0	92.2	0.89	0.86	0.8	48.7	8.0	2.9	3.6	81/68	0.057	184
WEX3-160L-2	18.5	-	32.5	18.8	2938	92.4	93.0	93.1	0.89	0.88	0.82	60.1	8.1	2.9	3.5	81/68	0.067	206
WEX3-180M-2	22	-	38.7	22.4	2953	92.7	93.1	93.1	0.89	0.88	0.82	71.1	8.2	2.2	2.3	83/70	0.098	238
WEX3-200L1-2	30	-	53.0	30.7	2970	93.3	93.6	93.2	0.89	0.88	0.82	96.5	7.5	2.2	2.3	84/71	0.20	310
WEX3-200L2-2	37	-	65	38	2968	93.7	94.1	93.5	0.89	0.87	0.81	119	7.5	2.2	2.3	84/71	0.23	320
WEX3-225M-2	45	-	78	45	2966	94.0	94.2	94.0	0.89	0.87	0.81	145	7.6	2.2	2.3	86/73	0.41	460
WEX3-250M-2	55	-	95	55	2969	94.3	94.7	94.3	0.89	0.88	0.82	177	7.6	2.2	2.3	89/75	0.48	510
WEX3-280S-2	75	-	128	74	2978	94.7	94.9	94.5	0.89	0.88	0.82	241	6.9	2.0	2.3	91/77	0.89	630
WEX3-280M-2	90	-	154	89	2978	95.0	95.1	94.8	0.89	0.88	0.82	289	7.0	2.0	2.3	91/77	1.08	705
WEX3-315S-2	110	-	187	108	2975	95.2	95.3	95.0	0.9	0.88	0.82	353	7.1	1.9	2.2	92/78	1.76	1070
WEX3-315M-2	132	-	224	130	2975	95.4	95.5	95.2	0.9	0.88	0.82	424	7.1	1.9	2.2	92/78	1.88	1100
WEX3-315L1-2	160	-	260	151	2975	95.6	95.8	95.3	0.91	0.88	0.82	514	7.1	1.9	2.2	92/78	2.077	1175
WEX3-315L-2	185	-	314	182	2976	95.7	95.8	95.6	0.91	0.88	0.82	594	7.1	1.9	2.2	92/78	2.35	1235
WEX3-315L2-2	200	-	333	193	2979	95.8	96.0	95.7	0.91	0.88	0.82	641	7.1	1.9	2.2	92/78	2.77	1395
WEX3-355S1-2	185	-	313	181	2987	95.8	95.8	95.4	0.91	0.88	0.82	591	7.1	1.9	2.2	100/85	3.46	1535
WEX3-355S2-2	200	-	333	193	2987	95.8	95.8	95.4	0.91	0.88	0.82	639	7.1	1.9	2.2	100/85	4.38	1690
WEX3-355M1-2	220	-	373	216	2986	95.8	95.9	95.5	0.91	0.88	0.82	704	7.1	1.8	2.2	100/85	4.38	1690
WEX3-355M2-2	250	-	419	243	2987	95.8	95.9	95.5	0.91	0.88	0.83	799	7.1	1.8	2.2	100/85	4.96	1785
WEX3-355L1-2	280	-	469	272	2985	95.8	95.9	95.5	0.91	0.88	0.83	896	7.1	1.8	2.2	100/85	4.97	1865
WEX3-355L2-2	315	-	520	301	2987	95.8	95.9	95.5	0.91	0.88	0.83	1007	7.1	1.8	2.2	100/85	5.95	2025
WEX3-355LX1-2	355	-	592	343	2988	95.8	95.9	95.5	0.91	0.88	0.83	1135	7.1	1.8	2.2	104/89	6.7	2165
WEX3-355LX2-2	375	-	628	364	2987	95.8	95.9	95.5	0.91	0.88	0.83	1199	7.1	1.8	2.2	104/89	6.7	2180

Performance data



10 50Hz 1500 min⁻¹ (4 pole)

Type	kW	I _N (A)			rpm	η (%)			cos Φ			T _N N.m	I _k / I _N	T _L / T _N	T _B / T _N	L _w / L _p dB(A)	kg·m ²	kg
		230V	400V	690V		1.0P _N	0.75P _N	0.5P _N	1.0P _N	0.75P _N	0.5P _N							
WEX3-80M1-4	0.55	2.26	1.3	-	1430	80.8	80.6	80.3	0.75	0.65	0.5	3.7	6.3	2.3	2.3	56/44	0.0024	34
WEX3-80M2-4	0.75	3.13	1.8	-	1435	82.5	83.7	82.1	0.75	0.66	0.51	5	6.5	2.3	2.3	56/44	0.003	36
WEX3-90S-4	1.1	4.35	2.5	-	1422	84.1	85.6	85.4	0.75	0.7	0.63	7.4	6.6	2.3	2.3	59/47	0.0036	41
WEX3-90L-4	1.5	5.91	3.4	-	1421	85.3	86.5	86.7	0.75	0.7	0.63	10.1	6.9	2.3	2.3	59/47	0.0045	46
WEX3-100L1-4	2.2	8.00	4.6	-	1447	86.7	86.9	86.2	0.81	0.76	0.64	14.5	7.5	2.3	2.3	64/52	0.011	45
WEX3-100L2-4	3	10.43	6.0	-	1442	87.7	88.4	87.5	0.82	0.77	0.67	19.9	7.6	2.3	2.3	64/52	0.014	55
WEX3-112M-4	4	-	7.9	4.6	1433	88.6	88.7	88.8	0.82	0.77	0.66	26.7	7.8	2.5	3.2	65/53	0.02	68
WEX3-132S-4	5.5	-	10.8	6.3	1457	89.6	90.2	89.7	0.82	0.77	0.67	36	7.5	2.0	2.3	71/59	0.033	91
WEX3-132M-4	7.5	-	14.9	8.6	1455	90.4	91.3	91.0	0.83	0.78	0.69	49.2	7.4	2.0	2.3	71/59	0.037	98
WEX3-160M-4	11	-	20.5	11.9	1469	91.4	92.3	91.6	0.85	0.81	0.7	71.5	7.5	2.2	2.3	73/60	0.094	187
WEX3-160L-4	15	-	27.7	16.1	1469	92.1	93.0	92.2	0.86	0.81	0.7	97.5	7.5	2.2	2.3	73/60	0.11	210
WEX3-180M-4	18.5	-	33.5	19.4	1479	92.6	92.9	92.6	0.86	0.81	0.71	119.4	7.0	2.3	2.8	76/63	0.21	249
WEX3-180L-4	22	-	40.0	23.2	1479	93.0	93.4	93.2	0.86	0.81	0.71	142	7.0	2.3	2.8	76/63	0.23	267
WEX3-200L-4	30	-	54	31	1478	93.6	94.0	93.6	0.86	0.82	0.72	193.8	7.2	2.2	2.3	76/63	0.42	300
WEX3-225S-4	37	-	65	38	1480	93.9	94.1	94.0	0.86	0.82	0.75	238.7	7.6	2.7	2.6	78/65	0.48566	430
WEX3-225M-4	45	-	79	46	1479	94.2	94.5	94.4	0.86	0.84	0.77	290.5	7.4	2.7	2.6	78/65	0.55258	460
WEX3-250M-4	55	-	95	55	1482	94.6	95.1	94.4	0.86	0.83	0.74	354.4	6.6	2.5	2.6	79/65	0.89251	520
WEX3-280S-4	75	-	130	75	1486	95.0	95.2	94.8	0.88	0.85	0.78	481.9	7.8	3.3	3.3	80/66	1.55032	655
WEX3-280M-4	90	-	160	93	1486	95.2	95.5	95.1	0.88	0.85	0.78	578.3	7.9	3.4	3.3	80/66	1.86355	730
WEX3-315S-4	110	-	187	108	1488	95.4	95.6	95.2	0.89	0.85	0.78	705.9	6.5	1.9	3.2	88/74	3.57097	1105
WEX3-315M-4	132	-	224	130	1489	95.6	95.8	95.3	0.89	0.85	0.78	846.5	6.9	2.2	3.4	88/74	4.20216	1185
WEX3-315L1-4	160	-	271	157	1487	95.8	96.0	95.5	0.89	0.85	0.78	1027.5	5.9	1.8	2.9	88/74	4.66295	1270
WEX3-315L-4	185	-	313	181	1487	95.9	96.0	95.6	0.89	0.85	0.78	1188	5.9	1.9	2.9	88/74	4.83418	1290
WEX3-315L2-4	200	-	338	196	1487	96.0	96.2	95.7	0.89	0.85	0.78	1284.3	5.9	1.9	2.9	88/74	5.42044	1420
WEX3-355S1-4	185	-	313	181	1490	96.0	96.2	95.7	0.89	0.85	0.78	1185.6	6.9	2.0	2.2	95/80	6.87719	1660
WEX3-355S2-4	200	-	339	197	1490	96.0	96.2	95.7	0.89	0.85	0.78	1281.7	6.9	2.0	2.2	95/80	7.6284	1740
WEX3-355M1-4	220	-	372	216	1490	96.0	96.2	95.7	0.89	0.85	0.78	1409.9	6.9	2.0	2.2	95/80	8.17419	1775
WEX3-355M2-4	250	-	422	245	1490	96.0	96.2	95.7	0.89	0.85	0.78	1602.2	6.9	2.0	2.2	95/80	8.56635	1830
WEX3-355L1-4	280	-	473	274	1489	96.0	96.2	95.7	0.89	0.85	0.78	1795.6	6.9	2.0	2.2	95/80	8.56198	1910
WEX3-355L2-4	315	-	532	308	1489	96.0	96.2	95.7	0.89	0.85	0.78	2020.1	6.9	2.0	2.2	95/80	9.85043	2040
WEX3-355LX1-4	355	-	600	348	1489	96.0	96.2	95.7	0.88	0.85	0.78	2276.6	6.9	2.0	2.2	102/87	10.59951	2115
WEX3-355LX2-4	375	-	634	368	1490	96.0	96.2	95.7	0.88	0.85	0.78	2403.3	6.9	2.0	2.2	102/87	12.42735	2295

Performance data



50Hz 1000 min⁻¹ (6 pole)

Type	kW	I _N (A)			rpm	η (%)			cos Φ			T _N N.m	I _s / I _N	T _L / T _N	T _B / T _N	L _w / L _p dB(A)	kg·m ²	kg
		230V	400V	690V		1.0P _N	0.75P _N	0.5P _N	1.0P _N	0.75P _N	0.5P _N							
WEX3-80M1-6	0.37	1.74	1.0	-	908	73.5	73.4	73.3	0.7	0.62	0.5	3.9	4.7	1.9	2	54/42	0.0031	25
WEX3-80M2-6	0.55	2.43	1.4	-	914	77.2	76.9	76.5	0.72	0.62	0.47	5.7	4.7	1.9	2.1	54/42	0.004	29
WEX3-90S-6	0.75	3.30	1.9	-	945	78.9	80.1	78.1	0.72	0.65	0.57	7.6	5.8	2.1	2.1	57/45	0.0058	42
WEX3-90L-6	1.1	4.70	2.7	-	939	81.0	81.4	80.5	0.73	0.66	0.57	11.2	5.9	2.1	2.1	57/45	0.0074	47
WEX3-100L-6	1.5	6.09	3.5	-	953	82.5	82.9	82.2	0.74	0.69	0.58	15	6.0	2.1	2.1	61/49	0.016	64
WEX3-112M-6	2.2	8.87	5.1	-	945	84.3	84.2	83.5	0.74	0.69	0.57	22.2	6.0	2.1	2.1	65/53	0.021	67
WEX3-132S-6	3	11.30	6.5	-	957	85.6	86.3	85.6	0.74	0.67	0.55	29.8	6.2	2.0	2.1	69/57	0.025	75
WEX3-132M1-6	4	-	8.6	5.0	958	86.8	87.6	87.2	0.74	0.68	0.56	39.7	6.8	2.0	2.1	69/57	0.035	89
WEX3-132M2-6	5.5	-	11.7	6.8	960	88.0	89.4	88.0	0.75	0.7	0.58	54.5	7.1	2.0	2.1	69/57	0.048	100
WEX3-160M-6	7.5	-	15.6	9.0	971	89.1	89.6	89.3	0.78	0.73	0.6	73.5	6.7	2.1	2.1	73/60	0.12	179
WEX3-160L-6	11	-	22.5	13.0	971	90.3	90.9	90.5	0.78	0.74	0.63	108	6.9	2.1	2.1	73/60	0.17	224
WEX3-180L-6	15	-	30.3	17.6	976	91.2	91.8	91.8	0.81	0.76	0.66	146	7.2	2.0	2.1	73/60	0.27	270
WEX3-200L1-6	18.5	-	38	22	982	91.7	92.2	92.0	0.81	0.76	0.67	179	7.2	2.1	2.1	73/60	0.41	285
WEX3-200L2-6	22	-	42	24	981	92.2	92.6	92.1	0.82	0.77	0.67	214	7.3	2.1	2.1	73/60	0.47	312
WEX3-225M-6	30	-	58	34	980	92.9	93.1	92.7	0.81	0.77	0.67	389	7.1	2.0	2.1	74/61	0.97	450
WEX3-250M-6	37	-	68	39	986	93.3	93.7	93.5	0.84	0.8	0.7	357	7.1	2.1	2.1	76/62	1.29	510
WEX3-280S-6	45	-	83	48	988	93.7	94.1	93.8	0.86	0.82	0.75	434	7.2	2.1	2.0	78/64	2.71	630
WEX3-280M-6	55	-	98	57	988	94.1	94.3	94.1	0.86	0.82	0.75	530	7.2	2.1	2.0	78/64	3.35	705
WEX3-315S-6	75	-	135	78	987	94.6	94.7	94.2	0.85	0.82	0.75	726	6.7	2.0	2.0	83/69	4.12	1090
WEX3-315M-6	90	-	160	93	987	94.9	95.1	94.6	0.84	0.82	0.75	871	6.7	2.0	2.0	83/69	4.87	1170
WEX3-315L1-6	110	-	196	114	987	95.1	95.2	94.8	0.85	0.82	0.75	1064	6.7	2.0	2.0	83/69	5.42	1255
WEX3-315L2-6	132	-	232	134	987	95.4	95.5	95.2	0.86	0.83	0.75	1277	6.7	2.0	2.0	83/69	6.44	1420
WEX3-355S-6	160	-	278	161	991	95.6	95.6	95.2	0.87	0.83	0.75	1542	6.7	2.0	2.0	85/70	10.10	1750
WEX3-355M1-6	185	-	321	186	990	95.7	95.9	95.4	0.87	0.83	0.75	1785	6.7	2.0	2.0	85/70	11.26	1840
WEX3-355M2-6	200	-	346	201	991	95.8	95.9	95.4	0.87	0.83	0.75	1927	6.7	2.0	2.0	85/70	12.45	1930
WEX3-355L1-6	220	-	394	228	991	95.8	95.9	95.4	0.87	0.83	0.75	2120	6.7	2.0	2.0	85/70	13.18	2075
WEX3-355L2-6	250	-	433	251	991	95.8	95.9	95.4	0.87	0.83	0.75	2409	6.7	2.0	2.0	85/76	14.82	2195
WEX3-355LX1-6	280	-	491	285	991	95.8	95.9	95.4	0.87	0.83	0.75	2698	6.7	2.0	2.0	91/76	15.52	2250
WEX3-355LX2-6	315	-	565	328	991	95.8	95.9	95.4	0.87	0.83	0.75	3036	6.7	2.0	2.0	91/76	15.99	2290

Performance data



12 50Hz 750 min⁻¹ (8 pole)

Type	kW	I _N (A)			rpm	η (%)			cos Φ			T _N N.m	I _k / I _N	T _L / T _N	T _B / T _N	L _w / L _p dB(A)	kg·m ²	kg
		230V	400V	690V		1.0P _N	0.75P _N	0.5P _N	1.0P _N	0.75P _N	0.5P _N							
WEX3-100L1-8	0.75	3.83	2.2	-	703	75.0	74.2	73.9	0.67	0.59	0.46	10.2	4.0	1.8	2.0	59/47	0.012	65
WEX3-100L2-8	1.1	5.22	3	-	714	77.7	77.2	76.7	0.67	0.6	0.46	14.7	5.0	1.8	2.0	59/47	0.016	72
WEX3-112M-8	1.5	6.61	3.8	-	719	79.7	78.8	78.1	0.71	0.62	0.49	19.9	5.0	1.8	2.0	61/49	0.023	64
WEX3-132S-8	2.2	9.57	5.5	-	712	81.9	80.4	80.0	0.71	0.63	0.5	29.5	6.0	1.8	2.0	64/52	0.029	103
WEX3-132M-8	3	12.35	7.1	-	713	83.5	82.2	81.5	0.73	0.65	0.51	40.2	6.0	1.8	2.0	64/52	0.04	122
WEX3-160M1-8	4	-	9.3	5.4	727	84.8	84.3	84.1	0.73	0.65	0.52	52.5	6.0	1.9	2.0	68/55	0.082	155
WEX3-160M2-8	5.5	-	12.4	7.2	726	86.2	85.9	85.7	0.74	0.67	0.54	72.3	6.0	1.9	2.0	68/55	0.1	169
WEX3-160L-8	7.5	-	16.5	9.6	728	87.3	87.0	86.8	0.75	0.69	0.56	98.4	6.0	1.9	2.0	68/55	0.14	206
WEX3-180L-8	11	-	23.9	13.9	734	88.6	88.4	88.1	0.75	0.69	0.56	143	6.5	2.0	2.0	70/57	0.26	268
WEX3-200L-8	15	-	31.8	18	734	89.6	89.2	89.0	0.76	0.69	0.57	195	6.6	2.0	2.0	73/60	0.51	359
WEX3-225S-8	18.5	-	39	23	737	90.1	89.8	89.7	0.76	0.7	0.58	240	6.6	1.9	2.0	73/60	0.76	431
WEX3-225M-8	22	-	49	28	737	90.6	90.2	90.0	0.78	0.72	0.6	285	6.6	1.9	2.0	73/60	0.87	392
WEX3-250M-8	30	-	60	35	739	91.3	91.0	90.8	0.79	0.72	0.6	388	6.5	1.9	2.0	75/61	1.34	480
WEX3-280S-8	37	-	74	43	742	91.8	91.4	91.2	0.79	0.75	0.63	476	6.6	1.9	2.0	76/62	2.48	615
WEX3-280M-8	45	-	89	52	743	92.2	92.0	91.5	0.79	0.75	0.63	578	6.6	1.9	2.0	76/62	3.00	630
WEX3-315S-8	55	-	110	64	741	92.5	92.2	92.0	0.8	0.76	0.65	709	6.6	1.8	2.0	82/68	4.41	1045
WEX3-315M-8	75	-	145	84	741	93.1	93.0	93.1	0.8	0.76	0.65	967	6.2	1.8	2.0	82/68	5.66	1155
WEX3-315L1-8	90	-	174	101	741	93.4	93.2	93.1	0.8	0.78	0.66	1160	6.4	1.8	2.0	82/68	6.74	1280
WEX3-315L2-8	110	-	207	120	741	93.7	93.5	93.4	0.82	0.78	0.66	1418	6.4	1.8	2.0	82/68	8.00	1440
WEX3-355S-8	132	-	242	140	745	94.0	93.8	93.5	0.82	0.78	0.66	1692	6.4	1.8	2.0	90/75	12.69	1790
WEX3-355M-8	160	-	299	173	745	94.3	94.2	94.0	0.82	0.78	0.67	2051	6.4	1.8	2.0	90/75	14.51	1910
WEX3-355L1-8	185	-	345	200	745	94.5	94.2	94.0	0.82	0.78	0.67	2371	6.4	1.8	2.0	90/75	16.09	2080
WEX3-355L2-8	200	-	368	213	745	94.6	94.2	94.0	0.83	0.78	0.67	2564	6.4	1.8	2.0	90/75	17.52	2180
WEX3-355LX1-8	220	-	404	234	745	94.6	94.2	94.0	0.83	0.78	0.67	2820	6.4	1.8	2.0	90/75	17.80	2200
WEX3-355LX2-8	250	-	460	267	744	94.6	94.2	94.0	0.83	0.78	0.67	3209	6.4	1.8	2.0	90/75	20.32	2365

Motor installation and dimensions



Foot (B3) mounting - frame sizes 80 to 355

IM B3
IM 1001
80 to 225

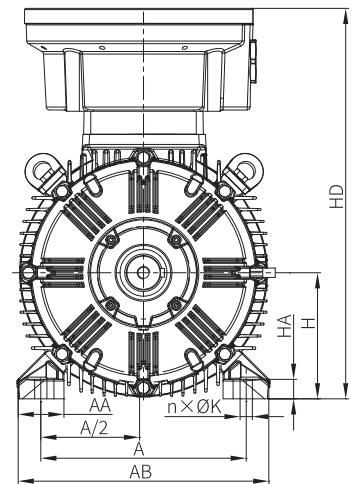
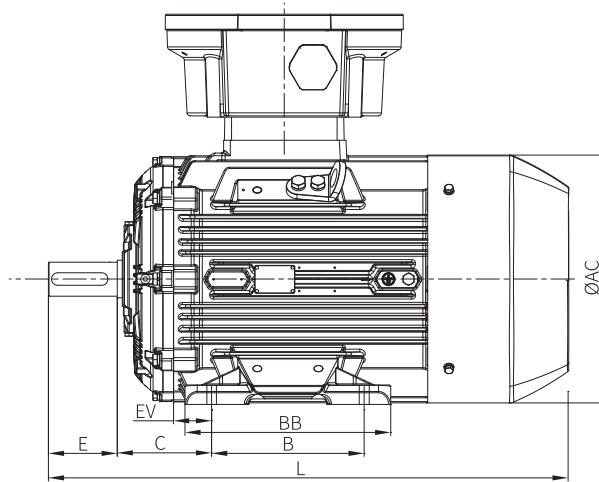

IM B3
IM 1001
250 to 355

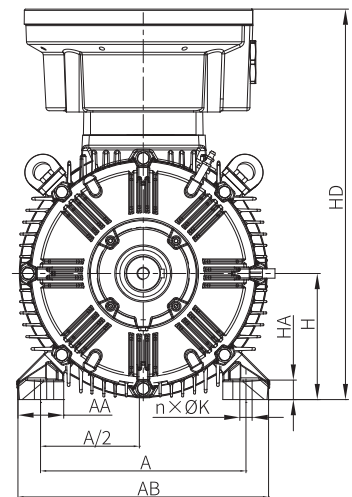
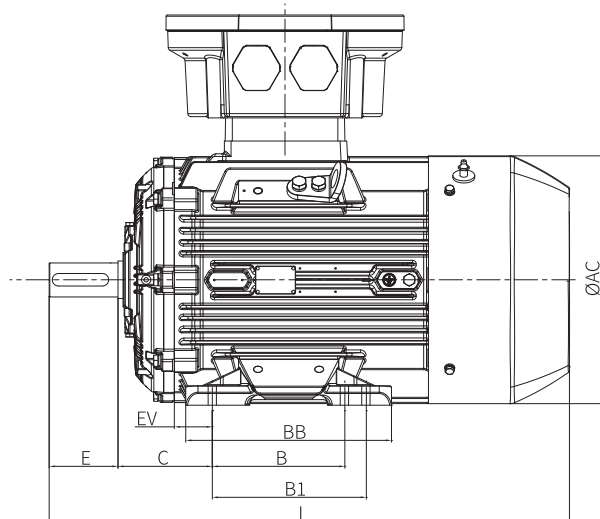

Motor installation and dimensions



14 Foot (B3) mounting

Frame size	Poles	Mounting dimensions (mm)								Outline dimensions (mm)													
		A	A/2	B1	B	C	H	n	K	AA	EV	AB	BB	HA	AC	HD		L					
		Ex db	eb	Ex db	eb																		
80M	2-8	125	62.5	-	100	50	80	4	10	32 ¹⁾	27.5 ²⁾	15 ¹⁾	15 ²⁾	157 ¹⁾	160 ²⁾	160 ¹⁾	130 ²⁾	10 ¹⁾	12 ²⁾	162	255	260	360
90S	2-8	140	70	-	100	56	90	4	10	37 ¹⁾	34 ²⁾	12 ¹⁾	15 ²⁾	172 ¹⁾	180 ²⁾	200 ¹⁾	155 ²⁾	12 ¹⁾	12 ²⁾	175	275	280	396
90L	2-8	140	70	-	125	56	90	4	10	37 ¹⁾	34 ²⁾	12 ¹⁾	15 ²⁾	172 ¹⁾	180 ²⁾	200 ¹⁾	155 ²⁾	12 ¹⁾	12 ²⁾	175	275	280	426
100L	2-8	160	80	-	140	63	100	4	12	45 ¹⁾	38 ²⁾	18 ¹⁾	17.5 ²⁾	200 ¹⁾	200 ²⁾	215 ¹⁾	175 ²⁾	15 ¹⁾	15 ²⁾	212	303	310	465
112M	2-8	190	95	-	140	70	112	4	12	45 ¹⁾	47 ²⁾	17 ¹⁾	17.5 ²⁾	228 ¹⁾	235 ²⁾	210 ¹⁾	175 ²⁾	15 ¹⁾	17 ²⁾	225	323	329	485
132S	2-8	216	108	-	140	89	132	4	12	56 ¹⁾	50 ²⁾	22 ¹⁾	23.5 ²⁾	262 ¹⁾	266 ²⁾	250 ¹⁾	187 ²⁾	18 ¹⁾	20 ²⁾	249	392	395	515
132M	2-8	216	108	-	178	89	132	4	12	56 ¹⁾	50 ²⁾	26 ¹⁾	23.5 ²⁾	262 ¹⁾	266 ²⁾	285 ¹⁾	225 ²⁾	18 ¹⁾	20 ²⁾	249	392	395	565
160M	2-8	254	127	-	210	108	160	4	14.5	65 ¹⁾	60 ²⁾	22 ¹⁾	23 ²⁾	314 ¹⁾	310 ²⁾	320 ¹⁾	256 ²⁾	20 ¹⁾	25 ²⁾	315	450	455	668
160L	2-8	254	127	-	254	108	160	4	14.5	65 ¹⁾	60 ²⁾	22 ¹⁾	23 ²⁾	314 ¹⁾	310 ²⁾	380 ¹⁾	300 ²⁾	20 ¹⁾	25 ²⁾	315	450	455	726
180M	2-8	279	139.5	-	241	121	180	4	14.5	68 ¹⁾	57 ²⁾	27 ¹⁾	23 ²⁾	349 ¹⁾	350 ²⁾	350 ¹⁾	325 ²⁾	22 ¹⁾	25 ²⁾	358	542	555	690
180L	2-8	279	139.5	-	279	121	180	4	14.5	68 ¹⁾	57 ²⁾	27 ¹⁾	23 ²⁾	349 ¹⁾	350 ²⁾	350 ¹⁾	325 ²⁾	22 ¹⁾	25 ²⁾	358	542	555	690
200L	2-8	318	159	-	305	133	200	4	18.5	84 ¹⁾	70 ²⁾	28 ¹⁾	30 ²⁾	388 ¹⁾	390 ²⁾	400 ¹⁾	365 ²⁾	25 ¹⁾	30 ²⁾	396	582	595	832
225S	4, 8	356	178	-	286	149	225	4	18.5	84 ¹⁾	82 ²⁾	33 ¹⁾	42 ²⁾	431 ¹⁾	450 ²⁾	425 ¹⁾	370 ²⁾	28 ¹⁾	35 ²⁾	445	627	680	925
225M	2	356	178	-	311	149	225	4	18.5	84 ¹⁾	82 ²⁾	33 ¹⁾	42 ²⁾	431 ¹⁾	450 ²⁾	465 ¹⁾	370 ²⁾	28 ¹⁾	35 ²⁾	445	627	680	935
225M	4-8	356	178	-	311	149	225	4	18.5	84 ¹⁾	82 ²⁾	33 ¹⁾	42 ²⁾	431 ¹⁾	450 ²⁾	465 ¹⁾	370 ²⁾	28 ¹⁾	35 ²⁾	445	627	680	965
250M	2	406	203	-	349	168	250	4	24	82 ¹⁾	85 ²⁾	48 ¹⁾	35.5 ²⁾	484 ¹⁾	510 ²⁾	465 ¹⁾	420 ²⁾	30 ¹⁾	35 ²⁾	496	732	740	968
250M	4-8	406	203	-	349	168	250	4	24	82 ¹⁾	85 ²⁾	48 ¹⁾	35.5 ²⁾	484 ¹⁾	510 ²⁾	465 ¹⁾	420 ²⁾	30 ¹⁾	35 ²⁾	496	732	740	968
280S	2	457	228.5	-	368	190	280	4	24	89 ¹⁾	100 ²⁾	61 ¹⁾	40.5 ²⁾	542 ¹⁾	570 ²⁾	495 ¹⁾	500 ²⁾	34 ¹⁾	40 ²⁾	555	792	800	1035
280S	4-8	457	228.5	-	368	190	280	4	24	89 ¹⁾	100 ²⁾	61 ¹⁾	40.5 ²⁾	542 ¹⁾	570 ²⁾	495 ¹⁾	500 ²⁾	34 ¹⁾	40 ²⁾	555	792	800	1035
280M	2	457	228.5	-	419	190	280	4	24	89 ¹⁾	100 ²⁾	61 ¹⁾	40.5 ²⁾	542 ¹⁾	570 ²⁾	545 ¹⁾	500 ²⁾	34 ¹⁾	40 ²⁾	555	792	800	1085
280M	4-8	457	228.5	-	419	190	280	4	24	89 ¹⁾	100 ²⁾	61 ¹⁾	40.5 ²⁾	542 ¹⁾	570 ²⁾	545 ¹⁾	500 ²⁾	34 ¹⁾	40 ²⁾	555	792	800	1085
315S	2	508	254	406	457	216	315	6	28	114 ¹⁾	146 ²⁾	50 ¹⁾	55.5 ²⁾	628 ¹⁾	636 ²⁾	620 ¹⁾	614 ²⁾	40 ¹⁾	40 ²⁾	627	915	1008	1230
315S	4-8	508	254	406	457	216	315	6	28	114 ¹⁾	146 ²⁾	50 ¹⁾	55.5 ²⁾	628 ¹⁾	636 ²⁾	620 ¹⁾	614 ²⁾	40 ¹⁾	40 ²⁾	627	915	1008	1260
315M	2	508	254	406	457	216	315	6	28	114 ¹⁾	146 ²⁾	50 ¹⁾	55.5 ²⁾	628 ¹⁾	636 ²⁾	620 ¹⁾	614 ²⁾	40 ¹⁾	40 ²⁾	627	915	1008	1230
315M	4-8	508	254	406	457	216	315	6	28	114 ¹⁾	146 ²⁾	50 ¹⁾	55.5 ²⁾	628 ¹⁾	636 ²⁾	620 ¹⁾	614 ²⁾	40 ¹⁾	40 ²⁾	627	915	1008	1260
315L1	2	508	254	457	508	216	315	6	28	114 ¹⁾	146 ²⁾	50 ¹⁾	55.5 ²⁾	628 ¹⁾	636 ²⁾	680 ¹⁾	614 ²⁾	40 ¹⁾	40 ²⁾	627	915	1008	1290
315L1	4-8	508	254	457	508	216	315	6	28	114 ¹⁾	146 ²⁾	50 ¹⁾	55.5 ²⁾	628 ¹⁾	636 ²⁾	680 ¹⁾	614 ²⁾	40 ¹⁾	40 ²⁾	627	915	1008	1320
315L	2	508	254	-	508	216	315	4	28	114 ¹⁾	146 ²⁾	50 ¹⁾	55.5 ²⁾	628 ¹⁾	636 ²⁾	800 ¹⁾	614 ²⁾	40 ¹⁾	40 ²⁾	627	915	1008	1410
315L	4	508	254	-	508	216	315	4	28	114 ¹⁾	146 ²⁾	50 ¹⁾	55.5 ²⁾	628 ¹⁾	636 ²⁾	680 ¹⁾	614 ²⁾	40 ¹⁾	40 ²⁾	627	915	1008	1440
315L2	2	508	254	-	508	216	315	4	28	114 ¹⁾	146 ²⁾	50 ¹⁾	55.5 ²⁾	628 ¹⁾	636 ²⁾	800 ¹⁾	614 ²⁾	40 ¹⁾	40 ²⁾	627	915	1008	1410
315L2	4, 8	508	254	-	508	216	315	4	28	114 ¹⁾	146 ²⁾	50 ¹⁾	55.5 ²⁾	628 ¹⁾	636 ²⁾	800 ¹⁾	614 ²⁾	40 ¹⁾	40 ²⁾	627	915	1008	1440
315L2	6	508	254	457	508	216	315	6	28	114 ¹⁾	146 ²⁾	50 ¹⁾	55.5 ²⁾	628 ¹⁾	636 ²⁾	680 ¹⁾	614 ²⁾	40 ¹⁾	40 ²⁾	627	915	1008	1320
355S	2	610	305	500	560	254	355	6	28	146 ¹⁾	171 ²⁾	81 ¹⁾	48 ²⁾	740 ¹⁾	727 ²⁾	810 ¹⁾	720 ²⁾	45 ¹⁾	50 ²⁾	720	1095	1215	1500
355S	4-8	610	305	500	560	254	355	6	28	146 ¹⁾	171 ²⁾	81 ¹⁾	48 ²⁾	740 ¹⁾	727 ²⁾	810 ¹⁾	720 ²⁾	45 ¹⁾	50 ²⁾	720	1095	1215	1530
355M	2	610	305	500	560	254	355	6	28	146 ¹⁾	171 ²⁾	81 ¹⁾	48 ²⁾	740 ¹⁾	727 ²⁾	810 ¹⁾	720 ²⁾	45 ¹⁾	50 ²⁾	720	1095	1215	1500
355M	4-8	610	305	500	560	254	355	6	28	146 ¹⁾	171 ²⁾	81 ¹⁾	48 ²⁾	740 ¹⁾	727 ²⁾	810 ¹⁾	720 ²⁾	45 ¹⁾	50 ²⁾	720	1095	1215	1530
355L	2	610	305	-	630	254	355	4	28	146 ¹⁾	171 ²⁾	46 ¹⁾	48 ²⁾	740 ¹⁾	727 ²⁾	920 ¹⁾	720 ²⁾	45 ¹⁾	50 ²⁾	720	1095	1215	1660
355L	4-8	610	305	-	630	254	355	4	28	146 ¹⁾	171 ²⁾	46 ¹⁾	48 ²⁾	740 ¹⁾	727 ²⁾	920 ¹⁾	720 ²⁾	45 ¹⁾	50 ²⁾	720	1095	1215	1690

Notes: a. 355L includes 355L1, 355L2, 355LX1, 355LX2.

b. 1) suitable for fixed foot design 2) suitable for universal foot design.

c. Please see page 19 for shaft information.

d. Ex db eb and Ex db motors differ in terminal box design and dimensions. Please see page 20 for terminal boxes information.

Motor installation and dimensions



Foot & flange (B35) mounting - frame sizes 80 to 355

IM B35
IM 2001
80 to 200

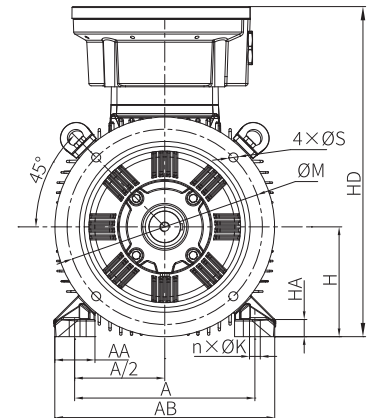
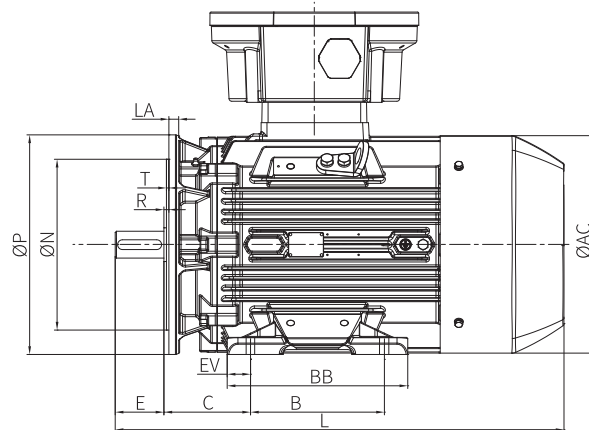

IM B35
IM 2001
225

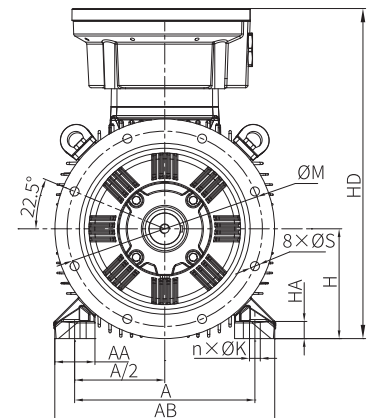
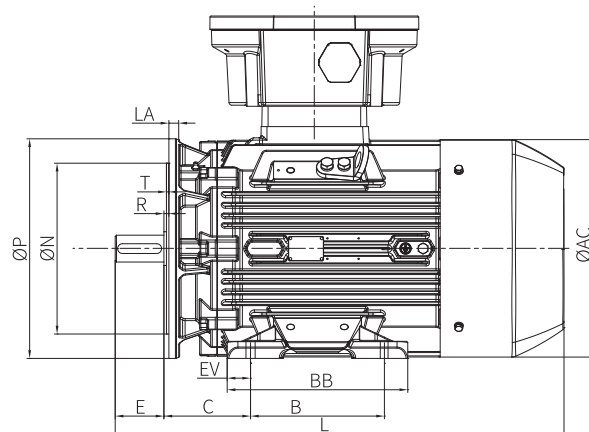

IM B35
IM 2001
250 to 355

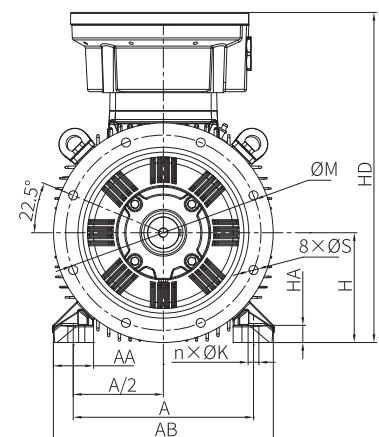
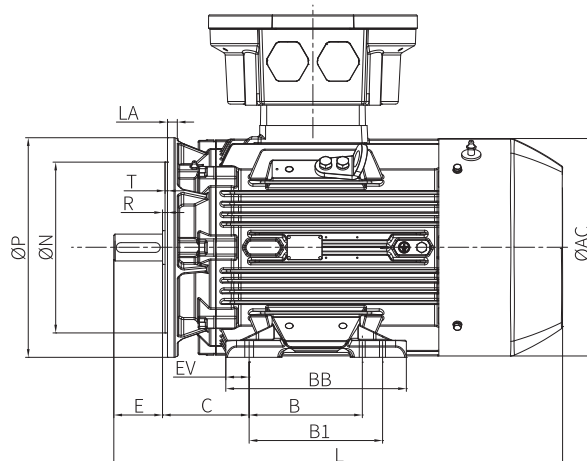

Motor installation and dimensions



16 Foot & flange (B35) mounting

Frame size	Poles	Mounting dimensions (mm)														Outline dimensions (mm)														
		A	A/2	B1	B	C	H	n	K	M	N	P	R	S	T	AA	EV	LA	AB	BB	HA	AC	HD		L					
		Ex db	eb	Ex db																										
80M	2-8	125	62.5	-	100	50	80	4	10	165	130	200	0	12	3.5	32 ¹⁾	27.5 ²⁾	15 ¹⁾	15 ²⁾	12	157 ¹⁾	160 ²⁾	160 ¹⁾	130 ²⁾	10 ¹⁾	12 ²⁾	162	255	260	360
90S	2-8	140	70	-	100	56	90	4	10	165	130	200	0	12	3.5	37 ¹⁾	34 ²⁾	12 ¹⁾	15 ²⁾	10	172 ¹⁾	180 ²⁾	200 ¹⁾	155 ²⁾	12 ¹⁾	12 ²⁾	175	275	280	396
90L	2-8	140	70	-	125	56	90	4	10	165	130	200	0	12	3.5	37 ¹⁾	34 ²⁾	12 ¹⁾	15 ²⁾	10	172 ¹⁾	180 ²⁾	200 ¹⁾	155 ²⁾	12 ¹⁾	12 ²⁾	175	275	280	426
100L	2-8	160	80	-	140	63	100	4	12	215	180	250	0	14.5	4	45 ¹⁾	38 ²⁾	18 ¹⁾	17.5 ²⁾	13	200 ¹⁾	200 ²⁾	215 ¹⁾	175 ²⁾	15 ¹⁾	15 ²⁾	212	303	310	465
112M	2-8	190	95	-	140	70	112	4	12	215	180	250	0	14.5	4	45 ¹⁾	47 ²⁾	17 ¹⁾	17.5 ²⁾	13	228 ¹⁾	235 ²⁾	210 ¹⁾	175 ²⁾	15 ¹⁾	17 ²⁾	225	323	329	485
132S	2-8	216	108	-	140	89	132	4	12	265	230	300	0	14.5	4	56 ¹⁾	50 ²⁾	22 ¹⁾	23.5 ²⁾	16	262 ¹⁾	266 ²⁾	250 ¹⁾	187 ²⁾	18 ¹⁾	20 ²⁾	249	392	395	515
132M	2-8	216	108	-	178	89	132	4	12	265	230	300	0	14.5	4	56 ¹⁾	50 ²⁾	26 ¹⁾	23.5 ²⁾	16	262 ¹⁾	266 ²⁾	285 ¹⁾	225 ²⁾	18 ¹⁾	20 ²⁾	249	392	395	565
160M	2-8	254	127	-	210	108	160	4	14.5	300	250	350	0	18.5	5	65 ¹⁾	60 ²⁾	22 ¹⁾	23 ²⁾	16	314 ¹⁾	310 ²⁾	320 ¹⁾	256 ²⁾	20 ¹⁾	25 ²⁾	315	450	455	668
160L	2-8	254	127	-	254	108	160	4	14.5	300	250	350	0	18.5	5	65 ¹⁾	60 ²⁾	22 ¹⁾	23 ²⁾	16	314 ¹⁾	310 ²⁾	380 ¹⁾	300 ²⁾	20 ¹⁾	25 ²⁾	315	450	455	726
180M	2-8	279	139.5	-	241	121	180	4	14.5	300	250	350	0	18.5	5	68 ¹⁾	57 ²⁾	27 ¹⁾	23 ²⁾	15	349 ¹⁾	350 ²⁾	350 ¹⁾	325 ²⁾	22 ¹⁾	25 ²⁾	358	542	555	690
180L	2-8	279	139.5	-	279	121	180	4	14.5	300	250	350	0	18.5	5	68 ¹⁾	57 ²⁾	27 ¹⁾	23 ²⁾	15	349 ¹⁾	350 ²⁾	350 ¹⁾	325 ²⁾	22 ¹⁾	25 ²⁾	358	542	555	690
200L	2-8	318	159	-	305	133	200	4	18.5	350	300	400	0	18.5	5	84 ¹⁾	70 ²⁾	28 ¹⁾	30 ²⁾	17	388 ¹⁾	390 ²⁾	400 ¹⁾	365 ²⁾	25 ¹⁾	30 ²⁾	396	582	595	832
225S	4, 8	356	178	-	286	149	225	4	18.5	400	350	450	0	18.5	5	84 ¹⁾	82 ²⁾	33 ¹⁾	42 ²⁾	22	431 ¹⁾	450 ²⁾	425 ¹⁾	370 ²⁾	28 ¹⁾	35 ²⁾	445	627	680	925
225M	2	356	178	-	311	149	225	4	18.5	400	350	450	0	18.5	5	84 ¹⁾	82 ²⁾	33 ¹⁾	42 ²⁾	22	431 ¹⁾	450 ²⁾	465 ¹⁾	370 ²⁾	28 ¹⁾	35 ²⁾	445	627	680	935
225M	4-8	356	178	-	311	149	225	4	18.5	400	350	450	0	18.5	5	84 ¹⁾	82 ²⁾	33 ¹⁾	42 ²⁾	22	431 ¹⁾	450 ²⁾	465 ¹⁾	370 ²⁾	28 ¹⁾	35 ²⁾	445	627	680	965
250M	2	406	203	-	349	168	250	4	24	500	450	550	0	18.5	5	82 ¹⁾	85 ²⁾	48 ¹⁾	35.5 ²⁾	22	484 ¹⁾	510 ²⁾	465 ¹⁾	420 ²⁾	30 ¹⁾	35 ²⁾	496	732	740	968
250M	4-8	406	203	-	349	168	250	4	24	500	450	550	0	18.5	5	82 ¹⁾	85 ²⁾	48 ¹⁾	35.5 ²⁾	22	484 ¹⁾	510 ²⁾	465 ¹⁾	420 ²⁾	30 ¹⁾	35 ²⁾	496	732	740	968
280S	2	457	228.5	-	368	190	280	4	24	500	450	550	0	18.5	5	89 ¹⁾	100 ²⁾	61 ¹⁾	40.5 ²⁾	22	542 ¹⁾	570 ²⁾	495 ¹⁾	500 ²⁾	34 ¹⁾	40 ²⁾	555	792	800	1035
280S	4-8	457	228.5	-	368	190	280	4	24	500	450	550	0	18.5	5	89 ¹⁾	100 ²⁾	61 ¹⁾	40.5 ²⁾	22	542 ¹⁾	570 ²⁾	495 ¹⁾	500 ²⁾	34 ¹⁾	40 ²⁾	555	792	800	1035
280M	2	457	228.5	-	419	190	280	4	24	500	450	550	0	18.5	5	89 ¹⁾	100 ²⁾	61 ¹⁾	40.5 ²⁾	22	542 ¹⁾	570 ²⁾	545 ¹⁾	500 ²⁾	34 ¹⁾	40 ²⁾	555	792	800	1085
280M	4-8	457	228.5	-	419	190	280	4	24	500	450	550	0	18.5	5	89 ¹⁾	100 ²⁾	61 ¹⁾	40.5 ²⁾	22	542 ¹⁾	570 ²⁾	545 ¹⁾	500 ²⁾	34 ¹⁾	40 ²⁾	555	792	800	1085
315S	2	508	254	406	457	216	315	6	28	600	550	660	0	24	6	114 ¹⁾	146 ²⁾	50 ¹⁾	55.5 ²⁾	22	628 ¹⁾	636 ²⁾	620 ¹⁾	614 ²⁾	40 ¹⁾	40 ²⁾	627	915	1008	1230
315S	4-8	508	254	406	457	216	315	6	28	600	550	660	0	24	6	114 ¹⁾	146 ²⁾	50 ¹⁾	55.5 ²⁾	22	628 ¹⁾	636 ²⁾	620 ¹⁾	614 ²⁾	40 ¹⁾	40 ²⁾	627	915	1008	1260
315M	2	508	254	406	457	216	315	6	28	600	550	660	0	24	6	114 ¹⁾	146 ²⁾	50 ¹⁾	55.5 ²⁾	22	628 ¹⁾	636 ²⁾	620 ¹⁾	614 ²⁾	40 ¹⁾	40 ²⁾	627	915	1008	1230
315M	4-8	508	254	406	457	216	315	6	28	600	550	660	0	24	6	114 ¹⁾	146 ²⁾	50 ¹⁾	55.5 ²⁾	22	628 ¹⁾	636 ²⁾	620 ¹⁾	614 ²⁾	40 ¹⁾	40 ²⁾	627	915	1008	1260
315L1	2	508	254	457	508	216	315	6	28	600	550	660	0	24	6	114 ¹⁾	146 ²⁾	50 ¹⁾	55.5 ²⁾	22	628 ¹⁾	636 ²⁾	680 ¹⁾	614 ²⁾	40 ¹⁾	40 ²⁾	627	915	1008	1290
315L1	4-8	508	254	457	508	216	315	6	28	600	550	660	0	24	6	114 ¹⁾	146 ²⁾	50 ¹⁾	55.5 ²⁾	22	628 ¹⁾	636 ²⁾	680 ¹⁾	614 ²⁾	40 ¹⁾	40 ²⁾	627	915	1008	1320
315L	2	508	254	-	508	216	315	4	28	600	550	660	0	24	6	114 ¹⁾	146 ²⁾	50 ¹⁾	55.5 ²⁾	22	628 ¹⁾	636 ²⁾	800 ¹⁾	614 ²⁾	40 ¹⁾	40 ²⁾	627	915	1008	1410
315L	4	508	254	-	508	216	315	4	28	600	550	660	0	24	6	114 ¹⁾	146 ²⁾	50 ¹⁾	55.5 ²⁾	22	628 ¹⁾	636 ²⁾	680 ¹⁾	614 ²⁾	40 ¹⁾	40 ²⁾	627	915	1008	1440
315L2	2	508	254	-	508	216	315	4	28	600	550	660	0	24	6	114 ¹⁾	146 ²⁾	50 ¹⁾	55.5 ²⁾	22	628 ¹⁾	636 ²⁾	800 ¹⁾	614 ²⁾	40 ¹⁾	40 ²⁾	627	915	1008	1410
315L2	4, 8	508	254	-	508	216	315	4	28	600	550	660	0	24	6	114 ¹⁾	146 ²⁾	50 ¹⁾	55.5 ²⁾	22	628 ¹⁾	636 ²⁾	800 ¹⁾	614 ²⁾	40 ¹⁾	40 ²⁾	627	915	1008	1440
315L2	6	508	254	457	508	216	315	6	28	600	550	660	0	24	6	114 ¹⁾	146 ²⁾	50 ¹⁾	55.5 ²⁾	22	628 ¹⁾	636 ²⁾	680 ¹⁾	614 ²⁾	40 ¹⁾	40 ²⁾	627	915	1008	1320
355S	2	610	305	500	560	254	355	6	28	740	680	800	0	24	6	146 ¹⁾	171 ²⁾	81 ¹⁾	48 ²⁾	25	740 ¹⁾	727 ²⁾	810 ¹⁾	720 ²⁾	45 ¹⁾	50 ²⁾	720	1095	1215	1500
355S	4-8	610	305	500	560	254	355	6	28	740	680	800	0	24	6	146 ¹⁾	171 ²⁾	81 ¹⁾	48 ²⁾	25	740 ¹⁾	727 ²⁾	810 ¹⁾	720 ²⁾	45 ¹⁾	50 ²⁾	720	1095	1215	1530
355M	2	610	305	500	560	254	355	6	28	740	680	800	0	24	6	146 ¹⁾	171 ²⁾	81 ¹⁾	48 ²⁾	25	740 ¹⁾	727 ²⁾	810 ¹⁾	720 ²⁾	45 ¹⁾	50 ²⁾	720	1095	1215	1500
355M	4-8	610	305	500	560	254	355	6	28	740	680	800	0	24	6	146 ¹⁾	171 ²⁾	81 ¹⁾	48 ²⁾	25	740 ¹⁾	727 ²⁾	810 ¹⁾	720 ²⁾	45 ¹⁾	50 ²⁾	720	1095	1215	1530
355L	2	610	305	-	630	254	355	4	28	740	680	800	0	24	6	146 ¹⁾	171 ²⁾	46 ¹⁾	48 ²⁾	25	740 ¹⁾	727 ²⁾	920 ¹⁾	720 ²⁾	45 ¹⁾	50 ²⁾	720	1095	1215	1660
355L	4-8	610	305	-	630	254	355	4	28	740	680	800	0	24	6	146 ¹⁾	171 ²⁾	46 ¹⁾	48 ²⁾	25	740 ¹⁾	727 ²⁾	920 ¹⁾	720 ²⁾	45 ¹⁾	50 ²⁾	720	1095	1215	1690

Note: a. The default flange is a round structure. If the user needs to cut the bottom edge of the flange due to limited installation space, it should be indicated in the purchase agreement.

b. 355L includes 355L1, 355L2, 355LX1, 355LX2.

c. 1) suitable for fixed foot design 2) suitable for universal foot design.

d. Please see page19 for shaft information.

e. Ex db eb and Ex db motors differ in terminal box design and dimensions. Please see page 20 for terminal boxes information.

Motor installation and dimensions



Flange, horizontal (B5) mounting - frame sizes 80 to 280
 Flange, shaft down (V1) mounting - frame sizes 80 to 355

IMB5/IMV1
 IM3001/IM3011
 80 to 200

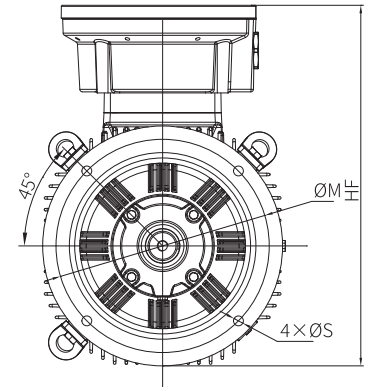
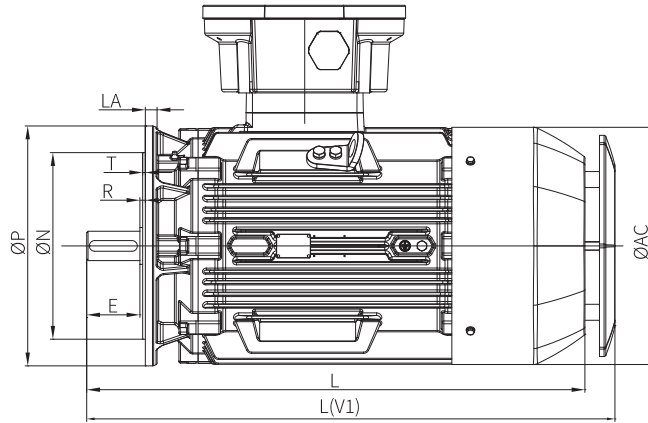

IMB5/IMV1
 IM3001/IM3011
 225 to 280

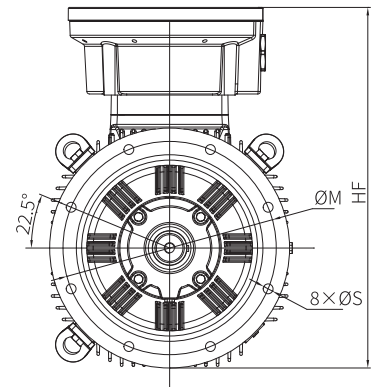
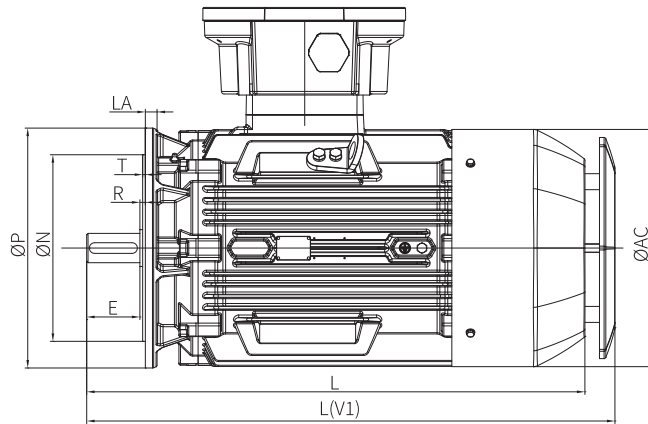

IMV1
 IM3011
 315 to 355

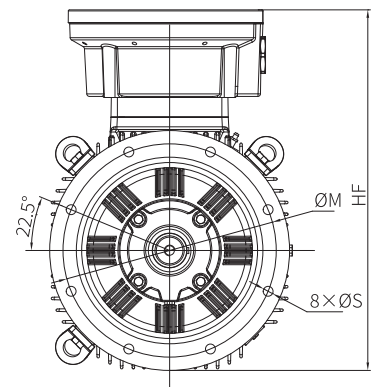
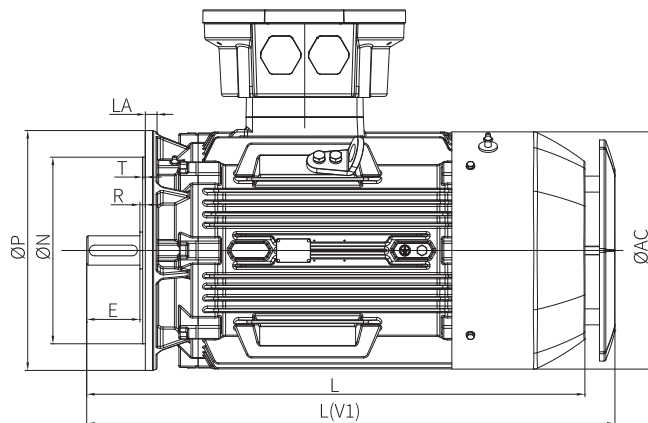

Motor installation and dimensions



18 Flange, horizontal (B5)/shaft down (V1) mounting

Frame size	Poles	Mounting dimensions (mm)								Outline dimensions (mm)				
		H	M	N	P	R	S	T	LA	AC	HF		L	L(V1)
											Ex db eb	Ex db		
80M	2-8	80	165	130	200	0	12	3.5	12	162	275	280	360	385
90S	2-8	90	165	130	200	0	12	3.5	10	175	285	290	426	455
90L	2-8	90	165	130	200	0	12	3.5	10	175	285	290	426	455
100L	2-8	100	215	180	250	0	14.5	4	13	212	328	335	465	490
112M	2-8	112	215	180	250	0	14.5	4	13	225	336	342	485	520
132S	2-8	132	265	230	300	0	14.5	4	16	249	410	413	515	560
132M	2-8	132	265	230	300	0	14.5	4	16	249	410	413	563	610
160M	2-8	160	300	250	350	0	18.5	5	16	315	465	470	670	730
160L	2-8	160	300	250	350	0	18.5	5	16	315	465	470	730	786
180M	2-8	180	300	250	350	0	18.5	5	15	358	537	550	690	750
180L	2-8	180	300	250	350	0	18.5	5	15	358	537	550	690	750
200L	2-8	200	350	300	400	0	18.5	5	17	396	582	595	830	910
225S	4, 8	225	400	350	450	0	18.5	5	22	445	627	680	965	1021
225M	2	225	400	350	450	0	18.5	5	22	445	627	680	935	990
225M	4-8	225	400	350	450	0	18.5	5	22	445	627	680	965	1020
250M	2	250	500	450	550	0	18.5	5	22	496	757	765	970	1050
250M	4-8	250	500	450	550	0	18.5	5	22	496	757	765	970	1050
280S	2	280	500	450	550	0	18.5	5	22	555	787	795	1085	1195
280S	4-8	280	500	450	550	0	18.5	5	22	555	787	795	1085	1195
280M	2	280	500	450	550	0	18.5	5	22	555	787	795	1085	1165
280M	4-8	280	500	450	550	0	18.5	5	22	555	787	795	1085	1165
315S	2	315	600	550	660	0	24	6	22	627	930	1023	1295	1375
315S	4-8	315	600	550	660	0	24	6	22	627	930	1023	1325	1405
315M	2	315	600	550	660	0	24	6	22	627	930	1023	1295	1375
315M	4-8	315	600	550	660	0	24	6	22	627	930	1023	1325	1405
315L	2	315	600	550	660	0	24	6	22	627	930	1023	1415	1495
315L	4-8	315	600	550	660	0	24	6	22	627	930	1023	1415	1525
355S	2	355	740	680	800	0	24	6	25	720	1140	1260	1500	1580
355S	4-8	355	740	680	800	0	24	6	25	720	1140	1260	1530	1610
355M	2	355	740	680	800	0	24	6	25	720	1140	1260	1500	1580
355M	4-8	355	740	680	800	0	24	6	25	720	1140	1260	1530	1610
355L	2	355	740	680	800	0	24	6	25	720	1140	1260	1660	1740
355L	4-8	355	740	680	800	0	24	6	25	720	1140	1260	1690	1770

Note: a. The default flange is a round structure. If the user needs to cut the bottom edge of the flange due to limited installation space, it should be indicated in the purchase agreement.

b. 355L includes 355L1, 355L2, 355LX1, 355LX2

c. Please see page 19 for shaft information.

d. Ex db eb and Ex db motors differ in terminal box design and dimensions. Please see page 20 for terminal boxes information.

Motor installation and dimensions



Foot & flange (B14) mounting - frame sizes 80 to 112

IMB 14/1MV18
IM3601/IM3611
80 to 112

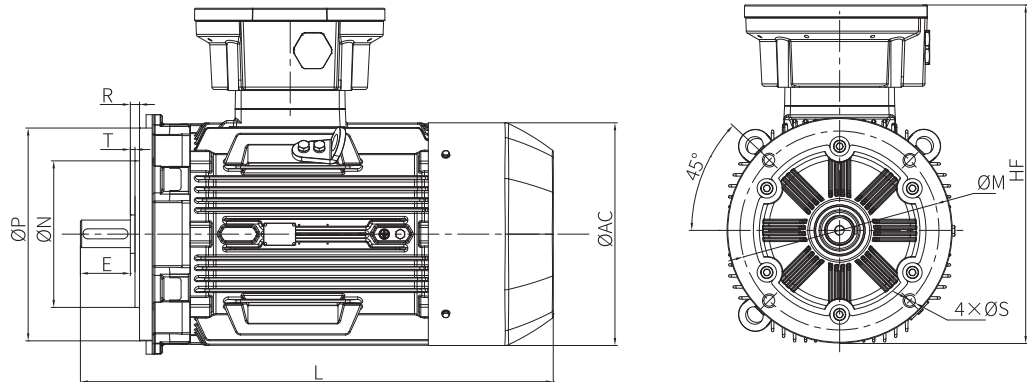

Frame size	Poles	Mounting dimensions (mm)						Outline dimensions (mm)			
		M	N	P	R	S	T	AC	HF		L
									Ex db eb	Ex db	
80M	2-8	100	80	120	0	M6	3.0	162	275	280	329
90S	2-8	115	95	140	0	M8	3.0	175	285	290	396
90L	2-8	115	95	140	0	M8	3.0	175	285	290	396
100L	2-8	130	110	160	0	M8	3.5	212	328	335	425
112M	2-8	130	110	160	0	M8	3.5	225	336	342	448

Note: Ex db eb and Ex db motors differ only in terminal box design and dimensions. Please see page 20 for terminal boxes information.

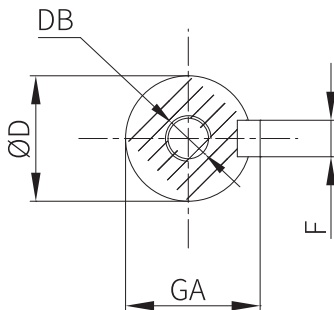

Shaft

Frame size	Poles	D	E	F	GA	DB
80	2-8	19	40	6	21.5	M6×20
90	2-8	24	50	8	27	M8×22
100 to 112	2-8	28	60	8	31	M10×22
132	2-8	38	80	10	41	M12×28
160	2-8	42	110	12	45	M12×28
180	2-8	48	110	14	51.5	M16×36
200	2-8	55	110	16	59	M20×42
225	2	55	110	16	59	M20×42
225	4-8	60	140	18	64	M20×42
250	2	60	140	18	64	M20×42
250	4-8	65	140	18	69	M20×42
280 to 315	2	65	140	18	69	M20×42
280	4-8	75	140	20	79.5	M20×42
315	4-8	80	170	22	85	M20×42
355	2	75	140	20	79.5	M24×50
355	4-8	95	170	25	90	M24×50

Shaft key

Frame size	Poles	Type A (b×h×l)	Grooving screw
80	2-8	6×6×32	-
90	2-8	8×7×40	-
100	2-8	8×7×50	-
112	2-8	8×7×50	-
132	2-8	10×8×70	-
160	2-8	12×8×90	M4
180	2-8	14×9×100	M5
200	2-8	16×10×100	M5
225	2	16×10×100	M5
225	4-8	18×11×125	M6
250	2-8	18×11×125	M6
280	2	18×11×125	M6
280	4-8	20×12×125	M6
315	2	18×11×125	M6
315	4-8	22×14×140	M6
355	2	20×12×125	M6
355	4-8	25×14×140	M8

Lifting lug

Frame size	Mounting type code	Lifting lug Quantity
80 to 355	B3, B35, B5, B14	2
80 to 355	V1	3

Motor stallation and dimensions



20

Terminal boxes

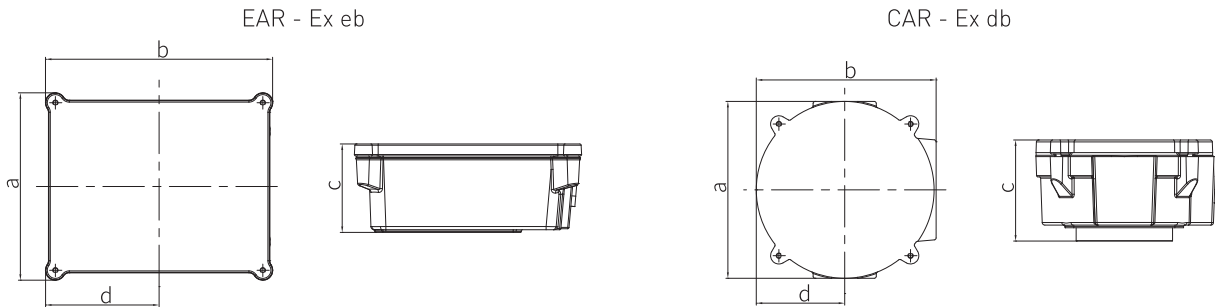

Frame size	EAR-Ex eb					CAR-Ex db					Gland specification	Cable entry	Lead wire terminal
		a	b	c	d		a	b	c	d			
80	EAR80	145	145	88	53	CAR80	145	145	92	53	1-M25×1.5	Ø11-Ø16	M5
90	EAR80	145	145	88	53	CAR80	145	145	92	53	1-M25×1.5	Ø11-Ø16	M5
100	EAR80	145	145	88	53	CAR80	145	145	92	53	1-M32×1.5	Ø15-Ø20	M5
112	EAR80	145	145	88	53	CAR80	145	145	92	53	1-M32×1.5	Ø15-Ø20	M5
132	EAR132	220	220	117	110	CAR132	220	220	103	110	1-M32×1.5	Ø15-Ø20	M6
160	EAR132	220	220	117	110	CAR132	220	220	103	110	1-M40×1.5	Ø19-Ø27	M6
180	EAR180	280	340	152	140	CAR180	265	270	162	133	1-M40×1.5	Ø19-Ø27	M8
200	EAR180	280	340	152	140	CAR180	265	270	162	133	1-M50×1.5	Ø26-Ø34	M8
225	EAR180	280	340	152	140	CAR225	380	380	202	190	1-M50×1.5	Ø26-Ø34	M8
250	EAR250	340	422	206	161	CAR225	380	380	202	190	2-M63×1.5	Ø35-Ø46	M12
280	EAR250	340	422	206	161	CAR225	380	380	202	190	2-M63×1.5	Ø35-Ø46	M12
315	EAR315	340	422	198	161	CAR315	484	492	293	242	2-M63×1.5	Ø35-Ø46	M12
355	EAR355	480	527	249	224	CAR355	484	740	371	242	2-M80×2	Ø48-Ø70	M16

Possible cross-sections with Ex e for low-voltage

Frame size	Rated cross-section, max. [mm ²]	Rated current, max. [A]	Terminal type	Number of terminals	Thread size
63 to 112	4	25	Clamp terminal ²⁾	6	M5
132 to 160	10	63	Clamp terminal ²⁾	6	M6
180 to 225	70	100	Saddle terminal ²⁾	6	M8
250 to 280	120	250	Saddle terminal ²⁾	6	M12
315	150	315 ¹⁾	Round terminal ²⁾	6	M12
355	300	400 ¹⁾	Round terminal ²⁾	6	M16
355	400	630 ¹⁾	Universal terminal ²⁾	6	M20

Note

1) Material: Cu

2) suitable for connection with and without cable lugs

3) suitable for connection with cable lugs



Mounting arrangements

Basic structural type	Foot mounted					
Mounting type code	B3	B6	B7	B8	V5	V6
Schematic diagram						
Frame size	80 to 355	80 to 160				

Basic structural type	FF flange mounted			Foot & FF flange options		
Mounting type code	B5	V1	V3	B35	V15	V36
Schematic diagram						
Frame size	80 to 280	80 to 355	80 to 160	80 to 355	80 to 160	

Basic structural type	FT flange mounted		Foot & FT flange mounted
Mounting type code	B14	V18	B34
Schematic diagram			
Frame size	80 to 112		

Ingress protection

WEX3 standard ingress protection is IP55. Depending on customer requirements, this range can be supplied with IP56, IP65 or IP66 ingress protection.

The protection level of the shell is mainly to prevent electric shock to human body or close to live parts or rotating parts, to prevent solid foreign matter from entering and to prevent harmful effects caused by water and oil. The code name and meaning of the protection form is shown in the table below.

Code	Meaning	First numeral	Meaning	Second numeral	Meaning
IP	Level of protection	5	Dust prevention	5	Protected against water spray (12.5L/min @ 0.3 bar)
		6	Dust tight	6	Protected against water jets or heavy seas (100L/min @ 1.0 bar)

Technical Description



Cooling method

The cooling methods for electrical machines are stated in code according to IEC 60034-6. The code consists of the letters IC (International Cooling) and a three-digit number.

The standard featured in this list are classified in the cooling method IC 411 (surface-cooled)

IC410 and IC416 cooling modes can be provided for special needs of users.

Insulation grade and temperature rise limit

Insulation grade and temperature rise limit (IEC60034-1)

Insulation grade	Limited temperature°C	The temperature rise limit K
B	130	80
F	155	105
H	180	125

WEX3 standard Insulation grade is F grade insulation, and the temperature rise limit is assessed as B grade ($\Delta 80K$), to further improve the service life in the power supply environment and service environment. Depending on customer requirements, this range can be supplied H grade insulation.

Noise levels

Noise levels are well below those specified in EN 60034-9. Noise measurements are performed according to EN ISO 1680 and EN 21680 according to class 2 in an anechoic room. The sound pressure level "Lp" and the sound power level "Lw" in dB(A) are indicated for the individual frame sizes in the operating datasheets. They apply for rated loads at 50 Hz, plus a tolerance of +3 dB(A). They apply for rated loads at 60Hz , 2P plus a tolerance of +5dB(A), and 4P or above: +3dB(A).

Vibration levels

Vibration limit (IEC60034-14)

Vibration severity grade	Mounting	Shaft center height H(mm)			
		$56 \leq H \leq 132$		$H > 132$	
		Displacement / μm	Speed /(mm/s)	Displacement / μm	Speed /(mm/s)
A	Free suspended mounting	45	2.8	45	2.8
	Rigid mounting	-	-	37	2.3
B	Free suspended mounting	18	1.1	29	1.8
	Rigid mounting	-	-	24	1.5

Note: Grade "A" is applicable to motors with no special requirements on vibration. It is the default configuration. Grade "B" for motors with special vibration requirements

Bearing



Bearing type

Frame sizes	Poles	Standard		Option 1		Option 2		Option 3	
		DE	NDE	DE	NDE	DE	NDE	DE	NDE
80	2-8	6204-2Z	6204-2Z	-	-	-	-	-	-
90	2-8	6205-2Z	6203-2Z	-	-	-	-	-	-
100	2-8	6206-2Z	6205-2Z	-	-	-	-	-	-
112	2-8	6206-2Z	6206-2Z	-	-	-	-	-	-
132	2-8	6208-2Z	6305-2Z	-	-	-	-	-	-
160	2-8	6309-2Z	6307-2Z	6309/C3	6307/C3	7309	6307	NU309	6307
180	2-8	6310-2Z	6308-2Z	6310/C3	6308/C3	7310	6308	NU310	6308
200	2-8	6312-2Z	6212-2Z	6312/C3	6212/C3	7312	6212	NU312	6212
225	2	6312-2Z	6312-2Z	6312/C3	6312/C3	7312	6312	NU312	6312
	4-8	6313-2Z	6312-2Z	6313/C3	6312/C3	7313	6312	NU313	6312
250	2	6313-2Z	6313-2Z	6313/C3	6313/C3	7313	6313	NU313	6313
	4-8	6314-2Z	6313-2Z	6314/C3	6313/C3	7314	6313	NU314	6313
280	2	6314-2Z	6314-2Z	6314/C3	6314/C3	7314	6314	NU314	6314
	4-8	6317-2Z	6314-2Z	6317/C3	6314/C3	7317	6314	NU317	6314
315	2	6316/C3	6316/C3	-	-	7316	6316	NU316	6316
	4-8	6319/C3	6319/C3	-	-	7319	6319	NU319	6319
355	2	6318/C3	6318/C3	-	-	7318	6318	NU318	6318
	4-8	6322/C3	6322/C3	-	-	7322	6322	NU322	6322

Note: 1. The standard configuration is deep groove ball bearing; H80-280 are sealed and maintainable, H315-355 are relubricated bearings;
 2. Optional 1: Re-lubricated bearing, suitable for H160-280 motors
 3. Optional 2: Angular contact ball bearing, which is mostly suitable for vertical installation of V1 and can bear larger axial load;
 4. Optional 3: Cylindrical roller bearing, which is mostly suitable for horizontal motor installation and can bear larger radial load.

Bearing location

Motor standard design:

H80-H132 Non-drive end designed as the located bearing.

H160-H355 Drive end designed as the located bearing.

Bearing

24



Lubrication

Maintenance free - sealed for life bearings

Mounting type	Frame sizes	Poles	RT _≤ 40°C
B3, B5, B35	80 to 280	2P	20000h
		4P	40000h

Relubrication intervals for horizontal construction type:

Mounting type	Frame sizes	Poles	Lubrication interval(h)			Grease quantity (g)
			40°C	50°C	60°C	
B3, B5, B35	160 to 355	2P	2500	1000	500	30
		4P	5000	2500	2000	40

Note: 1. The table data is applicable to 50Hz motor. For 60Hz motor, the time interval should be multiplied by 0.8;
 2. For vertical motor installation, the lubrication interval shall be divided by 2;
 3. Re-greasing intervals should be halved for every 15°C rise above 70°C.

Permissible forces at the shaft end

Maximum radial force (for pulley drive system): The maximum allowable radial force F₀(unit: N) for radial load is based on the premise that the load line (center of pulley) must be within the length of the motor shaft extension (the motor shaft elongation is shown in the installation size code E size). The radial force length X (mm) is the distance from the axial extension shoulder to the radial force F₀ action line, so when the length X= Max, it is the total length of the axial extension (size value E). Maximum allowable radial force as below table.

Frame sizes	Radial force F ₀ (N)							
	2P		4P		6P		8P	
	X=0	X=max	X=0	X=max	X=0	X=max	X=0	X=max
80	720	600	760	630	860	720	980	820
90	780	650	810	670	940	780	1060	880
100	1100	900	1110	910	1310	1070	1480	1210
112	1090	900	1080	890	1290	1060	1460	1200
132	1730	1360	1740	1400	2000	1610	2330	1880
160	2950	2330	3050	2410	3420	2700	3870	3060
180	3420	2740	3460	2820	4080	3320	4430	3610
200	4390	3640	4500	3730	5270	4370	5790	4800
225	4340	3620	5050	4030	5870	4690	6470	5170
250	4910	4000	5710	4650	6520	5310	7180	5840
280	5380	4500	6870	5750	8090	6770	9120	7630
315	6400	5550	7500	6310	8420	7080	9120	7670
355	6770	6070	8620	7560	9910	8690	11590	10160

Permissible radial force Frame sizes 80-355

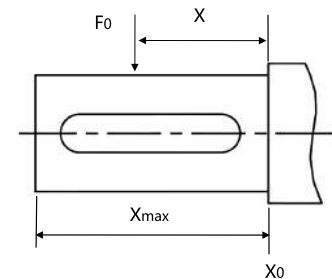

Bearing life

For standard ball bearings, under the action of allowable load, the bearing design life of the motor can meet the following requirements: at least 20000 hours for the 2-pole motor, 4 poles, 6 pole motor at least 30000 hours (refers to the motor life under normal operation at 50Hz and normal maintenance as required).

Optional accessories



Thermistor PTC

Name	PTC thermistor
Type	MZ6 145 D
Application	Motor overheating protection
Operating temperature and accuracy	145 ±5°C
Set position	1 in each phase, in series, at the highest temperature point embedded at the end of the winding at the drive end
Connection	Three components in series, two leads to the terminal box.
Color and marking of wiring	P1 & P2
Wiring diagram	
Frame	80 to 355

Note : (1) PTC operating temperature can be customized according to specifications
 (2) PTO thermosensitive bimetal switch can be used according to specifications.

Winding Resistant Temperature Detector (RTD)

Name	Platinum Resistant Temperature Detector (RTD)
Type	PT100, three leads
Application	Motor winding temperature detection, high temperature protection
0°C resistance and precision	100± 0.12Ω (Class B tolerances)
Set position	1 in each phase, at the highest temperature point embedded at the end of the winding at the drive end
Connection	Each component has three lead wires to the terminal box
Lead Markings	U – PU1, PU2, PU2 ; V– PVI, PV2, PV2; W– PW1, PW2, PW2. If there are two elements in each phase winding, the lead of the other element is marked as: U– PU3, PU4 , PU4 ; V– PV3, PV4, PV4 ; W– PW3, PW4, PW4
Wiring diagram	
Frame	160 to 355

Frequency Inverter Operation



Frequencies above the rated frequency of 50 Hz

If the frequency continues to increase beyond the drive's rated value, the speed increases accordingly. The speeds corresponding to the maximum frequencies must not exceed the motor's speed limit. If a motor is operated above its rated frequency, it will generate more noise.

Noise generation of three-phase motors in frequency inverter operation

Due to the harmonic oscillations, noise levels are higher in frequency inverter operation than they are at mains frequency. Without the use of a sinusoidal phase filter, the increase on the U-type inverter is about 7-15 dB(A); on the I-type inverter, it is about 3 dB(A). If a filter is used with the U-type inverter, the noise levels at frequencies < 50 Hz do not exceed the values with mains operation. The noise increase from self-ventilated motors at frequencies > 50 Hz can be taken from the following table. Guideline values for the increase of the sound pressure level through increase of the fan noise

F [Hz]	Δ LP [dB(A)]
50	0
60	≤ 5
70	≤ 9
80	≤ 12
87	≤ 15

Three phase motors operated with a frequency inverter at constant voltage above 50 Hz

If the motor runs above the mains frequency, at a constant voltage, field weakening occurs. The flux of the motor drops inversely proportion to the frequency. In the range above the rated frequency (50 Hz to 75 Hz), the motor's output remains approximately constant i.e. the torque drops inversely proportion to the frequency

Torque characteristic on the frequency inverter, 50 Hz mains, Temperature class T4

Torque characteristic	Decreasing quadratic constant	Constant torque		Constant power
frequency	5-50Hz	5-50Hz	25-50 Hz	50-75Hz
Control rang	1:10	10:1	1:2	1.5:1
Output/torque		75%T _N	100%T _N	100%P _N

Amb. -40°C~+ 50°C (H355,max ambient + 45°C)

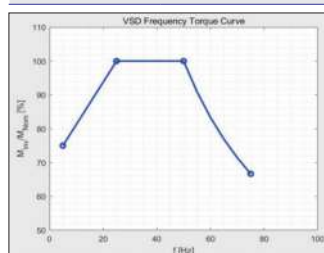

The following values of the permissible voltage loading capacity through voltage peaks (limit values of the terminals and winding insulation) are safe.

1. The air and creep sections of the terminals are designed for an effective rated voltage of 690 V on the basis of DIN EN 50019 - explosion protection type "Increased safety e". The permissible transient over voltage surge in frequency inverter operation of the motors is 2.15 kV phase-to-phase and phase-to-ground.
2. Standard windings for effective rated voltages up to 500 V have a peak-voltage resistance of 1.6kV phase-to-phase and phase-to-ground at continuous heating according to the heat class F. These motors can be used with frequency inverters with NO additional filter.
3. Standard windings for effective rated voltages of 690 V have a peak-voltage resistance of 1.6 kV phase-to-phase and phase-to-ground at continuous heating according to heat class F. These motors can be used with frequency inverters WITH an additional filter.
4. Special windings for an effective rated voltage of 690 V have a peak-voltage resistance of 2.15 kV phase-to- phase and phase-to-ground at continuous heating according to heat class F. These motors can be used with a frequency inverter WITHOUT additional filters. This special winding can be implemented in motors of frame size 315 or higher and requires a reduction of output. Efficiency according to manufacturer standard.

For more information on inverter operation, please consult instructions, inverter manufacturer or motor manufacturer. All performance characteristics according to IEC 60034-25:2014

Contact

Asia

Wolong Electric Group Co., LTD.

No.1801, Renmin West Road
Shangyu, Zhejiang, China
T +86 575 823 98874
F +86 575 821 76717
international@wolong.com
www.wolong-electric.com

Brook Crompton Asia Pacific Pte Ltd

19 Keppel Road #08-01, Jit Poh Building
Singapore 089058
T +65 6227 0308
F +65 6227 0605
marketing@brookcrompton-ap.com
www.brookcrompton.com

SINGAPORE

Controls & Electrics Pte. Ltd.
30 Gul Drive, Jurong Town.
Singapore 629478
Tel.: +65 6861 3377
Fax.: +65 6861 8408
sales@bousteadcontrols.com
www.bousteadcontrols.com

Europe

Wolong EMEA (Germany) GmbH

Schwalmsstraße 289
41238 Mönchengladbach, Germany
T +49 7182 14-1
F +49 7182 14-590
info-de@atb.wolong.com
www.wolong-electric.com

Brook Crompton UK Ltd

St. Thomas' Road
Huddersfield, HD1 3LJ, UK
T +44 (0)1484 557200
F +44 (0)1484 557201
csc@brookcrompton.com
www.brookcrompton.com

Americas

Brook Crompton Inc

1100 E. 222nd Street
Euclid, Ohio 44117, USA
T 1 - 800 - 668 - 6779
T 1 - 800 - 463 - 8917
sales@brookcromptonna.com
www.brookcromptonna.com

Brook Crompton Ltd

264 Attwell Drive
Toronto, Ontario, M9W 5B2, Canada
T 416-675-3844 (Toronto)
T 1-888-668-9843 (Quebec)
sales@brookcromptonna.com
www.brookcromptonna.com



Every care has been taken to ensure the accuracy of the information contained in this publication, but, due to a policy of continuous development and improvement the right is reserved to supply products which may differ slightly from those illustrated and described in this publication.

**BROOK
CROMPTON**
a **WOLONG** company

BC_ID_01_WEX3_202010_EN_VER3.1